



OCCUPATIONAL HEALTH HAZARD CONTROL

HENDRA



INTRODUCTION

The job of the industrial hygienist involves four major functions:

- 1. Anticipation of potential hazards*
- 2. Recognition*
- 3. Measurement*
- 4. Identification and recommendation of controls*

INTRODUCTION

- ✱ *The first principle: all hazards can be controlled.*
- ✱ *The second principle: there are usually many alternate methods of control.*
- ✱ *The third principle: some methods of control are better than others.*
- ✱ *The fourth principle: some situations will require more than one control method to obtain optimum results.*

HIERARCHY OF CONTROL

- ✱ *Basic concept of control approach*
- ✱ *First step to choose of control method*
- ✱ *Elements of hierarchy of control:*
 - ✱ *Engineering control*
 - ✱ *Administrative control*
 - ✱ *Personal protective equipment*

HIERARCHY OF CONTROL

- **Engineering control**

Pengendalian bahaya dengan melakukan modifikasi pada faktor lingkungan kerja selain pekerja

- **Administrative control**

Pengendalian bahaya dengan melakukan modifikasi pada interaksi pekerja dengan lingkungan kerja

- **Personal protective equipment**

Pengendalian bahaya dengan cara memberikan alat perlindungan yang digunakan oleh pekerja pada saat bekerja

POINT OF CONTROL

- ***At the Source***

- ***Air Path***

- ***Receiver***



Source

Air Path



Receiver

GENERALIZED DIAGRAM OF METHOD OF CONTROL

SOURCE	AIR PATH	RECEIVER
<ul style="list-style-type: none"> • SUBSTITUTION WITH A LESS HARMFUL MATERIAL (WATER IN PLACE OF ORGANIC SOLVENT) • CHANGE OF PROCESS (AIRLESS PAINT SPRAYING) • ENCLOSURE OF PROCESS (GLOVE BOX) • ISOLATION OF PROCESS (SPACE OR TIME) • WET METHODS (HYDRO BLAST) • LOCAL EXHAUST VENTILATION (CAPTURE AT SOURCE) • ADEQUATE MAINTENANCE PROGRAM 	<ul style="list-style-type: none"> • HOUSE KEEPING (IMMEDIATE CLEANUP) • GENERAL EXHAUST VENTILATION (ROOF FANS) • DILUTION VENTILATION (SUPPLIED AIR) • INCREASE DISTANCE BETWEEN SOURCE AND RECEIVER (SEMI AUTOMATIC OR REMOTE CONTROL) • CONTINUOUS AREA MONITORING (PRE-SET ALARM) • ADEQUATE MAINTENANCE PROGRAM 	<ul style="list-style-type: none"> • TRAINING & EDUCATION (MOST IMPORTANT) • ROTATION OF WORKERS (SPLIT UP DOSE) • ENCLOSURE OF WORKER (AIR CONDITIONED CRANE CABS) • PERSONAL MONITORING DEVICES (DOSIMETER) • PERSONAL PROTECTIVE DEVICES • ADEQUATE MAINTENANCE PROGRAM

ENGINEERING CONTROL

• Elimination

- *Remove the occupational health hazard from the workplace*
- *Stop process that can release some occupational health hazards*
- *Stop all employee activities in the risk area*

"Effective but some time not efficient"

ENGINEERING CONTROL

* Substitution

- * *Substitution of materials (Substitution of nontoxic or less toxic materials for highly toxic ones.)*

Detergent-and-water cleaning solutions or steam-cleaning processes can be used in place of solvents

A change in the physical condition of raw materials received by a facility for further processing may eliminate health hazards.

- *Palletized forms*
- *Briquette forms*

Are less dusty and can drastically reduce atmospheric dust contamination in some processes.

In the manufacture of pesticides, drugs, and solvents, and processes producing ionizing radiation, substitution may not be possible nor practical.

ENGINEERING CONTROL

* Substitution

- * *Substitution of process*

- *Ideal chance to concomitantly improve working conditions.*
- *Most made to improve quality or reduce the cost of production.*
- *Modified to reduce the dispersion of dust or fume, and consequently reduces the hazard.*

- * *Substitution of equipment*

Control occupational health hazard by change some equipment of process to reduce of hazard released

ENGINEERING CONTROL

✱ Isolation

- ♥ *Removing the source of the hazard exposure from the worker's environment by placing it in another location.*
- ♥ *Enclose or shield the source with physical barriers.*
- ♥ *Automate the process*
- ♥ *Removal and storage of these materials in a separate location.*

ENGINEERING CONTROL

✱ Isolation

- ☠ *Physical barriers. Ex. Acoustical soundproof booth with its own clean air supply.*
- ☠ *Time – through the use of remote control semiautomatic equipment.*
- ☠ *Proper storage and enclosure of hazardous materials.*
- ☠ *Designated location for activity or task either remote from other employees or as distant as possible from the greatest number of employees.*

ENGINEERING CONTROL

✱ Isolation

- *Off-shift or swing-shift scheduling of hazardous operations.*
- *Any scheduling which will minimize the number of workers exposed to a hazard.*
- *Equipment isolation – easiest method to prevent hazardous physical contact.*
- *Automation allows handling of equipment from remote location, especially useful when toxic materials are to be processed.*
- *Centralized control rooms.*
- *Total enclosure*

ENGINEERING CONTROL

✱ Minimization

An important principle in workplace where hazard are used is to reduce the hazard inventory as much as possible. This can be done by:

- *Reducing the amounts of hazardous plant being used*
- *Reducing the amounts of hazardous materials being stored*
- *Reducing the numbers of different hazards being stored*

Routine inventory audits, and disposal of off-specification, contaminated, out of date or no longer used stock and dismantling of plant no longer in use, will assist in this process.

ENGINEERING CONTROL

✱ Ventilation

- ☠ *Ventilation can be used to remove air pollutants from the breathing zone.*

- ☠ *It can also be used to condition the air for worker comfort.*

ENGINEERING CONTROL

✱ Ventilation

There are various categories of ventilation that can be used:

- A. Comfort Ventilation*
- B. Local exhaust ventilation (to remove contaminants that are generated at a local source)*
- C. Local supply ventilation (involves supplying air to a specific point or operation where it is required - can be used to provide spot cooling)*
- D. Make-up air (air supplied to the work environment to make up for air that is being exhausted through a local system)*

ENGINEERING CONTROL

✱ Ventilation

E. Dilution ventilation (diluting the pollutant - not applicable to highly toxic hazards which proves to be expensive in order to obtain desired results)

F. Natural ventilation (air movement created by thermal differences)

- ✱ The ventilation system that is installed in a traffic tunnel to eliminate carbon monoxide buildup is an example of a dilution ventilation system.
- ✱ Exhausting polluting materials away from a plant through stacks is an example of both natural ventilation and dilution ventilation.



Local Exhaust Ventilation

Figure 18-9. The fumes arising from lead-melting operations are controlled by local lateral-slot exhaust ventilation. (Courtesy Ford Motor Co.)

Local exhaust ventilation

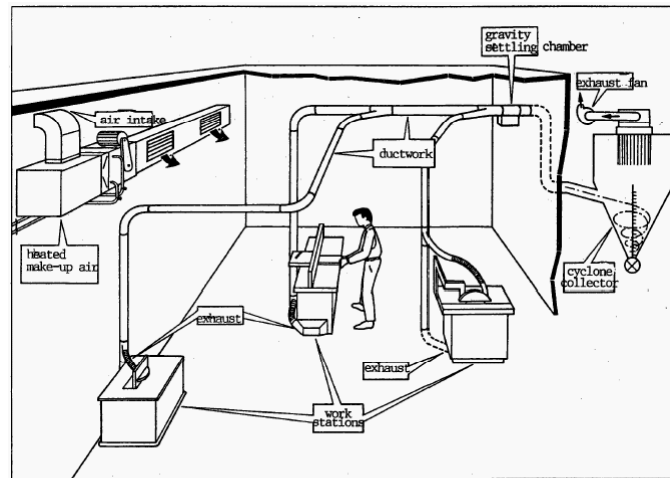

Figure 7-3 Schematic representation of a classical exhaust ventilation system in the woodworking industry (INRS, 1992; by courtesy of INRS)

ENGINEERING CONTROL AT SOURCE

- *Automation*
- *Total process enclosure*
- *Guarding of machinery*
- *Mechanical handling*
- *Special storage facilities*
- *Ventilation*
- *Etc.*

Enclosure

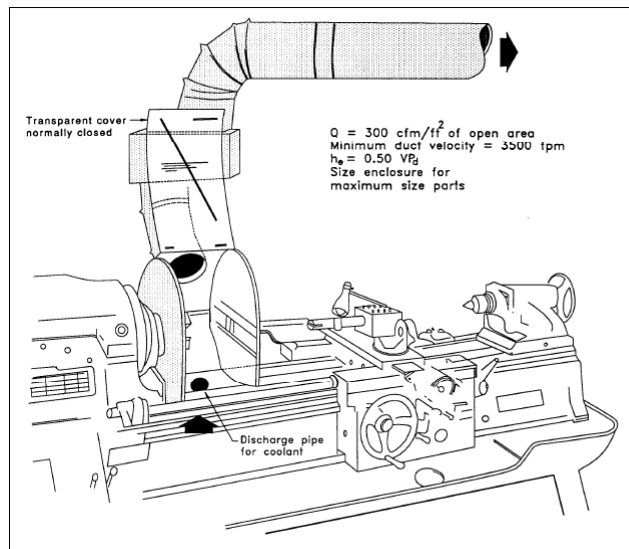

Figure 19-3. Design details for an enclosure from the *ACGIH Manual*. (Source: From American Conference of Governmental Industrial Hygienists (ACGIH®), *Industrial Ventilation: A Manual of Recommended Practice*, 23rd ed. Copyright 1998, Cincinnati. Reprinted with permission.)

ENGINEERING CONTROL TO REDUCE EXPOSURE

- * *Partial or temporary enclosure*
- * *Spray booths*
- * *Fume cupboards*
- * *Glove boxes*
- * *Dilution or local exhaust ventilation*
- * *Pre wetting*
- * *Etc.*

Dilution ventilation

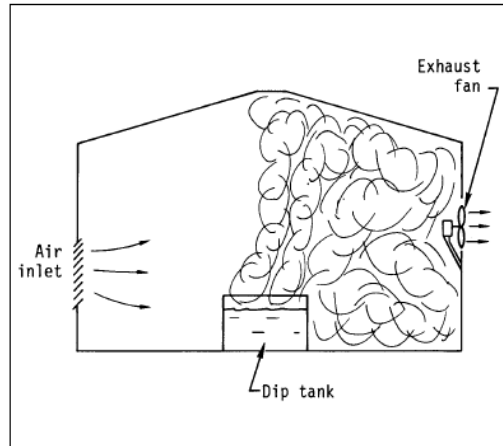

Figure 20-1. Dilution ventilation gradually removes contaminants dispersed in the workroom air.

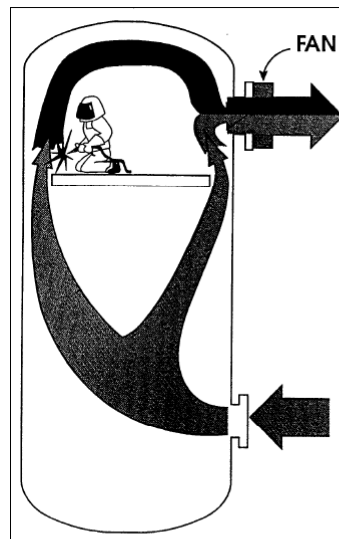

Figure 20-5. The dilution ventilation must work with natural air movement such as the convective rise due to solar heat load on this process vessel. (Courtesy ExxonMobil Corporation.)

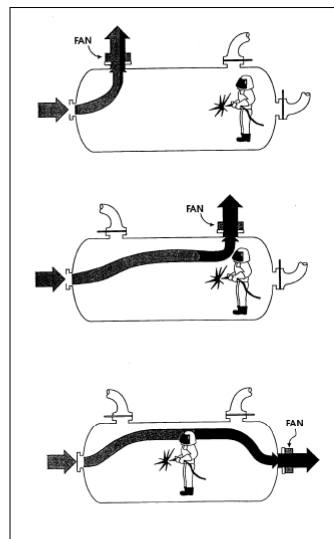

Figure 20-6. Short circuiting (top) reduces the effectiveness of dilution ventilation. Relocating the fan and make-up air entry ports can help to solve the problem. (Courtesy ExxonMobil Corporation.)

ADMINISTRATIVE CONTROL

- ✱ *These controls are usually effective when used with one of the other control methods previously outlined.*
- ✱ *Examples include worker training, monitoring the work area or the worker, scheduling workers into the area, good housekeeping, and preventive maintenance.*

ADMINISTRATIVE CONTROL

- ✱ *Training can be used to provide workers with methods and procedures that are useful in avoiding hazards and to develop error avoidance behaviors in workers.*
- ✱ *Monitoring the work area or worker includes the continuous monitoring of equipment and the use of personnel samplers or dosimeters.*

ADMINISTRATIVE CONTROL

- ✱ *Biological monitoring of workers determine if a worker has been exposed to a hazard - can involve pre and post employment medical exams.*
- ✱ *Rotation of worker schedules in and out of hazardous areas during a shift.*
- ✱ *Good housekeeping control hazards through cleanliness of the workplace.*

ADMINISTRATIVE CONTROL

- ✱ *Preventative maintenance schedules in order to avoid possible malfunctions of equipment.*
- ✱ *Other administrative controls include reports and statistics that are gathered from previous work-related injuries and the existence of adequate emergency aid and procedures.*

PERSONAL PROTECTIVE EQUIPMENT

PPE (Alat pelindung diri) merupakan alat atau sarana yang digunakan oleh pekerja yang melekat pada tubuh pekerja dengan tujuan untuk melindungi sebagian atau seluruh tubuh pekerja pada saat melaksanakan pekerjaan dari kemungkinan terpajan oleh bahaya yang melebihi batas yang diperbolehkan.

FUNGSI PPE

- ☠ *Hanya untuk melindungi pekerja*
- ☠ *Tidak untuk mengendalikan bahaya tapi untuk menurunkan tingkat risiko*
- ☠ *Sebagai salah satu metode pengendalian paparan bahaya di tempat kerja*
- ☠ *Alternatif terakhir dalam mengendalikan paparan bahaya di tempat kerja*

TUJUAN PEMAKAIAN PPE

- *Melindungi pekerja dari pajanan bahaya (menghindari pajanan)*
- *Sebagai pembatas antara pekerja dengan bahaya (menghindari kontak)*
- *Mencegah masuknya bahaya ke dalam tubuh pekerja (membatasi intake)*
- *Melindungi pekerja dari pajanan bahaya yang melebihi nilai ambang batas (membatasi dosis)*

PERSONAL PROTECTIVE EQUIPMENT

- *Personal protective equipment should be used as a last resort and a temporary measure until more permanent controls can be installed.*
- *Protective equipment should be tested to assure it will do the job for which it was designed which is to provide minimum interference with the job being done.*

PERSONAL PROTECTIVE EQUIPMENT

- ✱ *Personal protective equipment can be categorized as follows:*
 - a. *Skin protection*
 - b. *Eye protection*
 - c. *Ear protection*
 - d. *Respiratory protection*
 - e. *Other protection - safety shoes, diving suits, and environmental control suits*

Skin protection

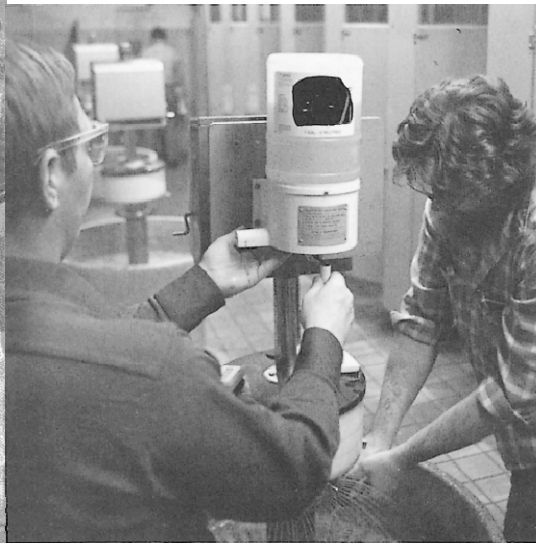

Figure 18-12. Industrial hand cleansers are available as plain soap powders, abrasive soap cakes, liquids, cream soaps, and waterless hand cleansers.

Figure 18-11. To minimize worker contact with harmful chemical agents, hand-washing facilities must be conveniently located.

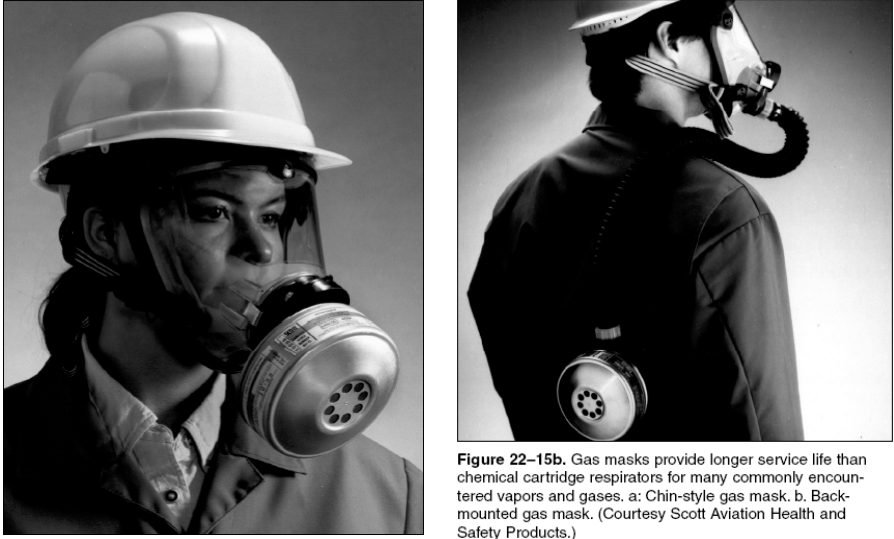

Figure 22-15b. Gas masks provide longer service life than chemical cartridge respirators for many commonly encountered vapors and gases. a: Chin-style gas mask. b: Back-mounted gas mask. (Courtesy Scott Aviation Health and Safety Products.)

@ Hendra "Higiene Industri" Program Sarjana 35



Figure 22-18. Powered air-purifying respirators with hoods or helmets can be worn by workers with beards and/or eyeglasses. (Courtesy 3M.)

Figure 22-22. A continuous flow air-line respirator with a helmet with a viewing lens adapter for welding. (Courtesy 3M.)

@ Hendra "Higiene Industri" Program Sarjana 36

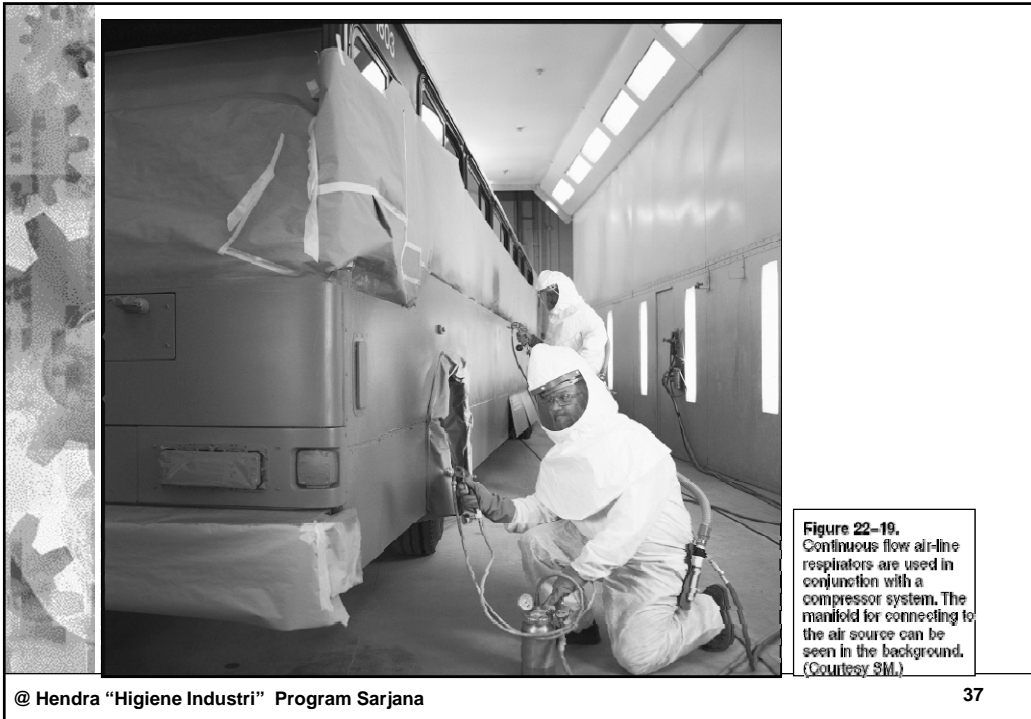

Figure 22-19. Continuous flow air-line respirators are used in conjunction with a compressor system. The manifold for connecting to the air source can be seen in the background. (Courtesy SMI.)

Determining the Control Method to Use - The Approach

- 1. Be sure that the hazard has been identified correctly***
- 2. Identify alternate methods for controlling the hazard***
- 3. Determine which alternative(s) provide the best solution to the problem***
- 4. The best alternative should be selected***
- 5. Implement the control(s)***
- 6. Periodic follow-up***

Determining the Control Method to Use - The Approach cont.

- ❑ *Anticipation of potential hazards is an integral part of the control procedure which is to be involved in the planning stages.*
- ❑ *Many companies have implement a system requiring that drawings or specifications be approved by the health professional before use.*
- ❑ *The engineering department, with the help of the health professional, should check with the purchasing department to determine the necessary safety and health measures.*

MATRIX OF CONTROL

Point of Control Hierarchy of Control	<i>Source</i>	<i>Air Path</i>	<i>Receiver</i>
<i>Engineering Control</i>	<i>Control available</i>	<i>Control available</i>	
<i>Administrative Control</i>	<i>Control available</i>	<i>Control available</i>	<i>Control available</i>
<i>PPE</i>			<i>Control available</i>



THANK YOU